



MANUAL CHANGE OF FILTERS AND MEMBRANE

PRODUCT: P4MV50-GOLD



1-Sediment Filter: Made of polypropylene, porosity of 5 microns. It retains mud, dirt, sand, rust and any particles larger than 5 microns. The status of this filter should be checked every 3 months, if the color or color saturation is too dark should be replaced.

2- Granular Carbon Filter: Grains of activated carbon from vegetable coconut shells, removes chlorine, organic matter, impurities and chemical compounds. Neutralizes odor and taste.

3- Carbon Filter Block: Mesh block of activated carbon from coconut shell, porosity of 5 microns. It removes chlorination by-products, organic matter, impurities, neutralizes odor and taste.

4- Reverse Osmosis Membrane: Polyamide Membrane, 50GPD, Eliminates chloramines, fluoride, lead, organic matter, bacteria, viruses, Micro-plastics, PFAS, PFOS, heavy metals...

5-Post-filter Activated Carbon: Activated coconut shell powder carbon, designed to optimize the taste of the water after purification and storage in the tank.

- THESE UNIVERSAL FILTERS AND REPLACEMENT MEMBRANE, FOR NON-COMPACT 5-STAGE EQUIPMENT. THEY MUST BE REPLACED AT LEAST ONCE A YEAR. THE MEMBRANE CAN BE USED UP TO 2 YEARS AS LONG AS THE WATER OUTPUT TDS OF THE EQUIPMENT ARE BELOW 100PPM.
- A MINIMUM DURATION CANNOT BE ESTABLISHED AS IT DEPENDS ON THE SATURATION, SALINITY OF THE WATER TO BE PURIFIED AND THE NUMBER OF LITERS PURIFIED.
- IT IS RECOMMENDED TO CHECK THE AIR PRESSURE OF THE TANK IN VACUUM, TAKING ADVANTAGE OF THE FILTER CHANGE, SO THAT IT IS RECOMMENDED BY THE TANK MANUFACTURER. THIS INFORMATION IS USUALLY INDICATED ON THE FRONT LABEL OF THE TANK.

-



WARNINGS:

BEFORE UNSEALING THE FILTERS, VERIFY THAT BOTH THE FILTERS AND THE MEMBRANE ARE COMPATIBLE WITH YOUR EQUIPMENT.

IF THE FILTERS ARE IN POOR CONDITION, TAMPERING OR PREVIOUS USE IS APPRECIATED, AS WELL AS IF ANY OF THE WRAPPERS ARE TAMPERED WITH, DO NOT USE THEM AND RETURN THEM TO YOUR SUPPLIER.

DO NOT USE THIS PRODUCT WITH MICROBIOLOGICALLY UNKNOWN OR UNCONTROLLED WATER.

THE MEMBRANE OF THIS ASSEMBLY IS 50 GPD, IT MUST BE VERIFIED PRIOR TO REPLACEMENT, THAT YOUR EQUIPMENT USES 50GPD MEMBRANE. REPLACING THE MEMBRANE WITH A DIFFERENT MODEL THAN THE ONE INSTALLED AS STANDARD OR RECOMMENDED BY THE MANUFACTURER MAY CAUSE MALFUNCTIONS AND/OR BREAKAGES IN YOUR EQUIPMENT.

THESE FILTERS AND MEMBRANE ARE DESIGNED FOR USE WITH MAINS DRINKING WATER ONLY.

IT IS RECOMMENDED TO SANITIZE THE EQUIPMENT WITH 3% HYDROGEN PEROXIDE, EVERY 6 MONTHS OF USE AND EACH INTERVENTION TO CHANGE FILTERS AND/OR MEMBRANE.

DO NOT EXPOSE TO A PRESSURE GREATER THAN 6 BAR.

OPERATING TEMPERATURE RANGE: 5°C TO 40°C.

CONTAINS SMALL PARTS, DO NOT LEAVE WITHIN REACH OF CHILDREN.



TOOLS NEEDED:

Small wrench to adjust side connections.

Tongs.

Sterile gloves.

Filter holder wrench

Membrane carrier wash



PRECAUTIONS:

IF YOUR REVERSE OSMOSIS EQUIPMENT HAS AN ELECTRICAL CURRENT, YOU MUST DISCONNECT IT FROM THE MAINS THROUGHOUT THE EQUIPMENT HANDLING PROCESS.

TURN OFF THE WATER INLET TAP TO THE REVERSE OSMOSIS EQUIPMENT.

OPEN THE TAP OF THE REVERSE OSMOSIS EQUIPMENT, WAIT FOR IT TO EMPTY COMPLETELY AND STOP WATER COMING OUT.



INSTALLATION:

Locate the vessel of the first stage of filtration, sediment filter. With the corresponding key, the glass will be opened. It should be taken into account that it is very possible that some water will come out of the joint of the pool, even if the system has been drained.



Once opened, remove the filter to be replaced, clean the inside of the glass with soap and water. Unseal the sediment filter and insert it into the vessel.

It is important that it coincides at the lower and upper slits so that the vessel closes correctly.

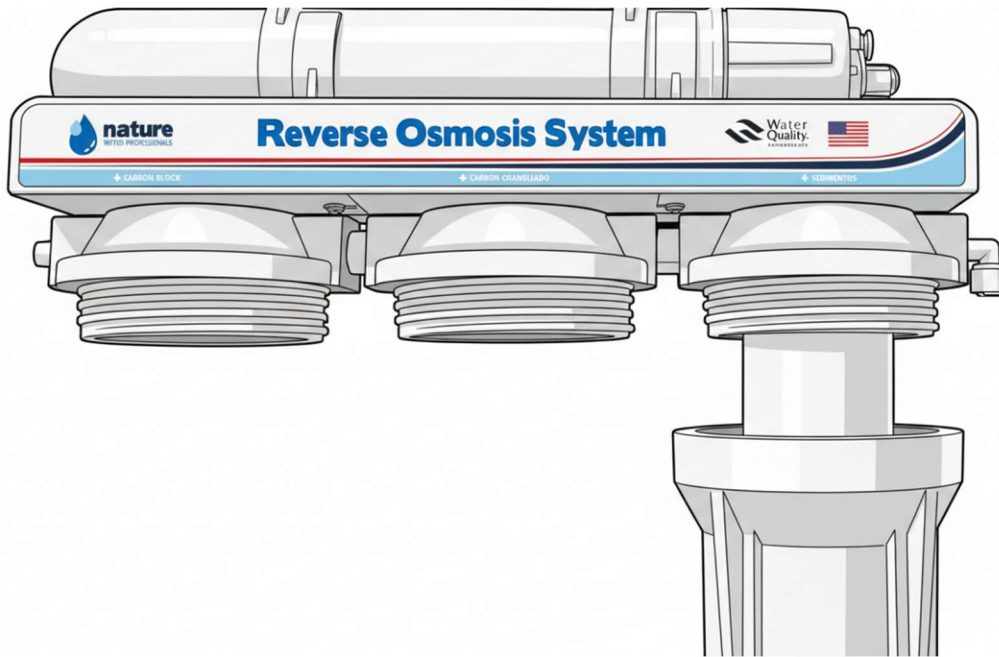

Subsequently, the same operation will be carried out with the other two filters, Granular Carbon and Carbon Block.

The only filter that has a specific sense for placement inside the vessel is the central filter, Granular Carbon. It must be installed, leaving the white rubber gasket at the top of the glass.



These two filters are recommended to be rinsed prior to installation to remove traces of carbon dust.

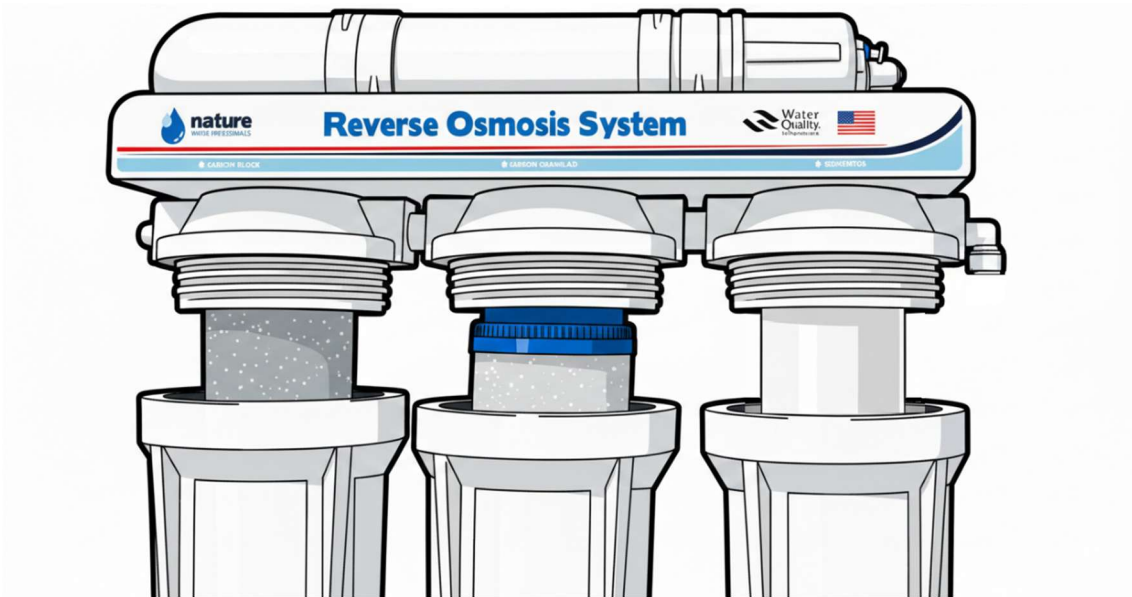

Once the 3 vertical filters have been installed, the membrane will be changed.

The tube supplying the membrane holder must be disconnected with the corresponding key, and the membrane holder cover must be unscrewed. With the help of pliers, the membrane will be removed. It is recommended to clean the inside of the membrane holder with soapy water and rinse to leave no residue.

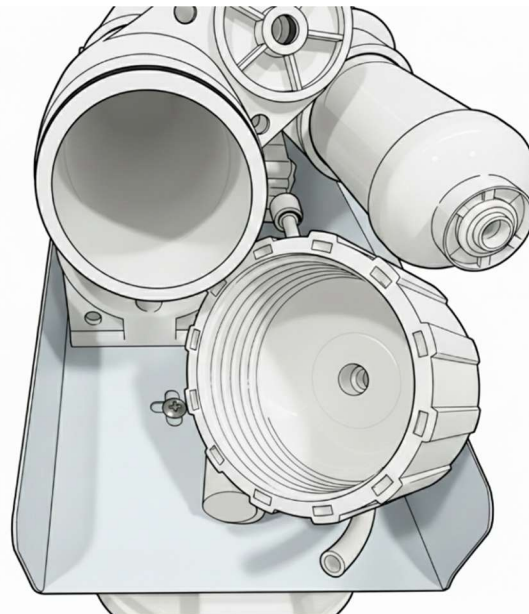

IT IS IMPORTANT TO REMEMBER THAT THE MEMBRANE SHOULD NOT COME INTO CONTACT WITH ANY ELEMENT THAT COULD CONTAMINATE IT. STERILE GLOVES MUST BE WORN TO HANDLE IT.

Insert the membrane, first inserting the end with 2 small O-rings on the inside.

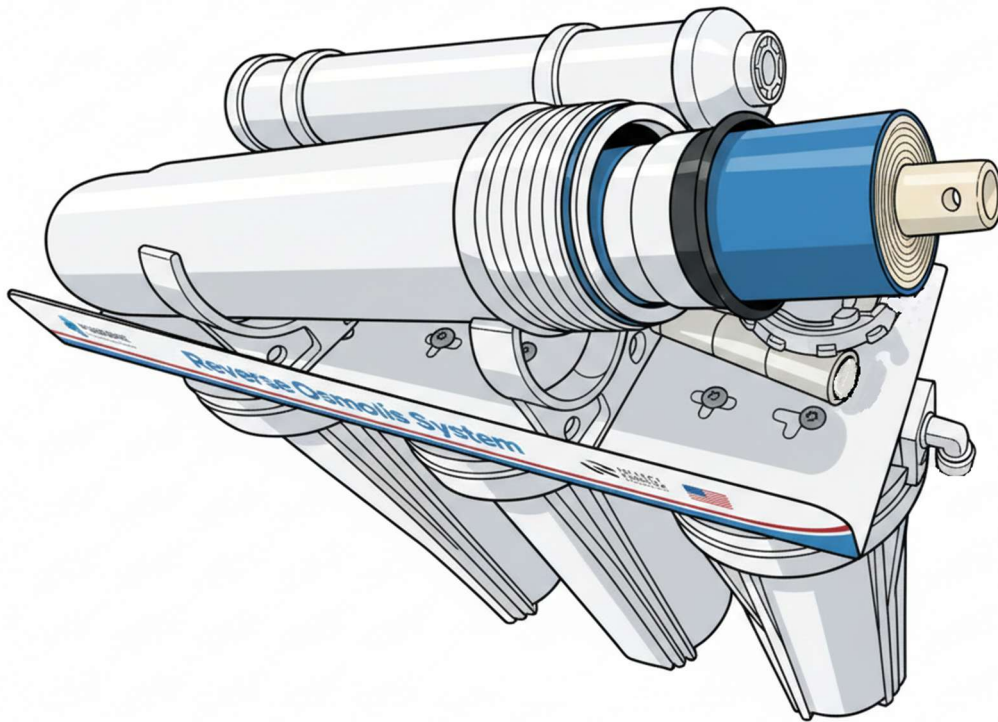

Attach the membrane holder cover, adjust with the wrench and reconnect the pipe.

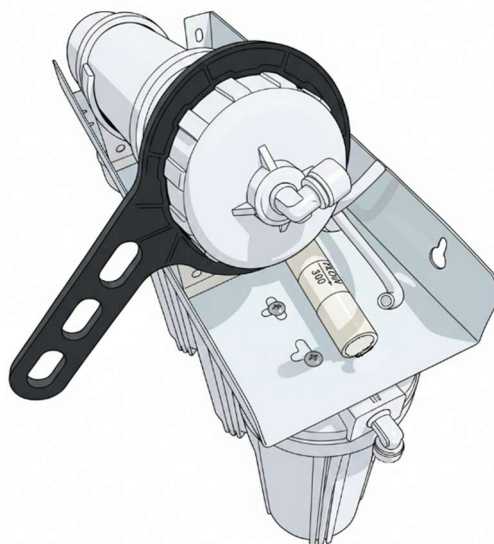

For the post-filter change, the pipes at the ends will be disconnected and thus free the filter. In the filter set you can find connections and Teflon. You can use the parts added in the kit or reuse those from your post-filter.

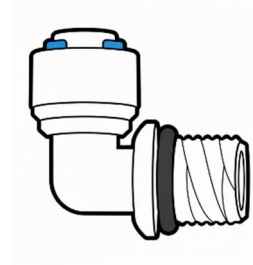
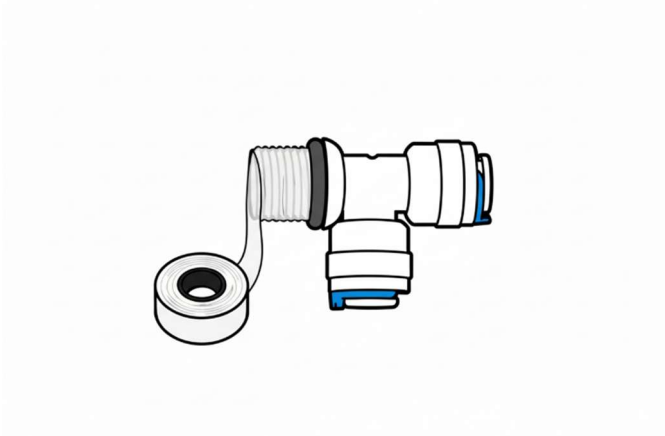

If you are using the supplied parts, you must first locate the T and one of the O-rings. Insert the gasket through the threaded part of the T until you reach the stop.

Unseal the filter, remove the side protective caps.

Apply 6/7 turns of Teflon to the thread, screw the T onto the end of the post-filter marked with the word "EQUIPMENT".



The pipe that comes from the membrane holder with the purified water and the pipe that connects to the tank must be connected to this tee.

Locate an elbow, perform the same operation of inserting the O-ring and apply Teflon, screw on the end indicated with "TAP". We will connect the pipe that supplies the service tap of the osmosis equipment.



The supplied connections are quick to insert, for this the blue clips are removed, the pipe is inserted, exerting pressure to the top and reinserting the safety clips in place.



It will be checked that all the vessels and membrane holder have been securely closed and that all the connections are made.

SANITIZATION AND PROCESS COMPLETION

In the first glass, 250ml of 3% hydrogen peroxide (hydrogen peroxide) will be added inside the glass together with the sediment filter. The cup will be adjusted to its initial position with the key.

The osmosis water outlet tap will be closed, the osmosis socket inlet will be opened, if your equipment has a pump it will be connected to the electrical network. We will wait for the tank to fill up and the system to stop. Let the hydrogen peroxide act for 15-20 minutes. After this time, the system will be completely emptied, waiting for hardly any water to come out of the osmosis equipment tap. This rinse should be done 2 to 3 times to remove the sanitizing agent.

Once the rinses have been done, the water can be consumed.

- It is normal that the first time the equipment is rinsed the water has a grayish color, it is the carbon dust of the post-filter has to settle.
- It is normal that during the first days of use the water presents small translucent particles, they are air bubbles trapped in the membrane, letting the water stand for a few minutes disappears.

- If the taste or smell after changing the filters is not pleasant, perform some more rinsing, if it continues, do not consume the water and contact the technical assistance service.

ALMACEN OSMOSIS, SL.

CIF: B06976161

CALLE RIO VINALOPÓ, 15. NAVE D-10

46930 QUART DE POBLET, VALENCIA, SPAIN.

contacto@almacenosmosis.com

Phone: 960491493



nature[®]
WATER PROFESSIONALS