



MANUAL FILTER CHANGE

PRODUCT: P5GOLD



1- Sediment Filter: Made of polypropylene, porosity of 5 microns. It retains mud, dirt, sand, rust and any particles larger than 5 microns. The status of this filter should be checked every 3 months, if the color or saturation is too dark it should be replaced.

2- Granular Carbon Filter: Grains of activated carbon from vegetable coconut shells, removes chlorine, organic matter, impurities and chemical compounds. Neutralizes odor and taste.

3- Carbon Filter Block: Mesh block of activated carbon from coconut shell, porosity of 5 microns. It removes chlorination by-products, organic matter, impurities, neutralizes odor and taste.

4- Activated Carbon Postfilter: Activated coconut shell powder carbon, designed to optimize the taste of the water after purification and storage in the tank.

5- Remineralizing Filter: Conglomerate of natural compounds, which provide Calcium, Potassium, Sodium and Magnesium to the purified water. Essential elements for the body to hydrate optimally and naturally.

- THESE UNIVERSAL REPLACEMENT FILTERS, FOR NON-COMPACT 6-STAGE EQUIPMENT, SHOULD BE REPLACED AT LEAST ONCE A YEAR.
- IF THE TDS OF YOUR MEMBRANE EXCEEDS 100PPM IT MUST BE REPLACED.
- A MINIMUM DURATION CANNOT BE ESTABLISHED AS IT DEPENDS ON THE SATURATION, SALINITY OF THE WATER TO BE PURIFIED AND THE NUMBER OF LITERS PURIFIED.
- IT IS RECOMMENDED TO CHECK THE AIR PRESSURE OF THE TANK IN VACUUM, TAKING ADVANTAGE OF THE FILTER CHANGE, SO THAT IT IS RECOMMENDED BY THE TANK MANUFACTURER. THIS INFORMATION IS USUALLY INDICATED ON THE FRONT LABEL OF THE TANK.



WARNINGS:

BEFORE UNSEALING THE FILTERS, VERIFY THAT THEY ARE COMPATIBLE WITH YOUR EQUIPMENT.

IF THE FILTERS ARE IN POOR CONDITION, TAMPERING OR PREVIOUS USE IS APPRECIATED, AS WELL AS IF ANY OF THE WRAPPERS ARE TAMPERED WITH, DO NOT USE THEM AND RETURN THEM TO YOUR SUPPLIER.

DO NOT USE THIS PRODUCT WITH MICROBIOLOGICALLY UNKNOWN OR UNCONTROLLED WATER.

THESE FILTERS ARE DESIGNED FOR USE WITH MAINS DRINKING WATER ONLY.

IT IS RECOMMENDED TO SANITIZE THE EQUIPMENT WITH 3% HYDROGEN PEROXIDE, EVERY 6 MONTHS OF USE AND EACH INTERVENTION TO CHANGE FILTERS AND/OR MEMBRANE.

DO NOT EXPOSE TO A PRESSURE GREATER THAN 6 BAR.

OPERATING TEMPERATURE RANGE: 5°C TO 40°C.

CONTAINS SMALL PARTS, DO NOT LEAVE WITHIN REACH OF CHILDREN.



TOOLS NEEDED:

Small wrench to adjust side connections.

Filter holder wrench.



PRECAUTIONS:

IF YOUR REVERSE OSMOSIS EQUIPMENT HAS AN ELECTRICAL CURRENT, YOU MUST DISCONNECT IT FROM THE MAINS THROUGHOUT THE EQUIPMENT HANDLING PROCESS.

TURN OFF THE WATER INLET TAP TO THE REVERSE OSMOSIS EQUIPMENT.

OPEN THE TAP OF THE REVERSE OSMOSIS EQUIPMENT, WAIT FOR IT TO EMPTY COMPLETELY AND STOP WATER COMING OUT.



INSTALLATION:

Locate the vessel of the first stage of filtration, sediment filter. With the corresponding key, the glass will be opened. It should be taken into account that it is very possible that some water will come out of the joint of the pool, even if the system has been drained.



Once opened, remove the filter to be replaced, clean the inside of the glass with soap and water. Unseal the sediment filter and insert it into the vessel.

It is important that it coincides at the lower and upper slits so that the vessel closes correctly.

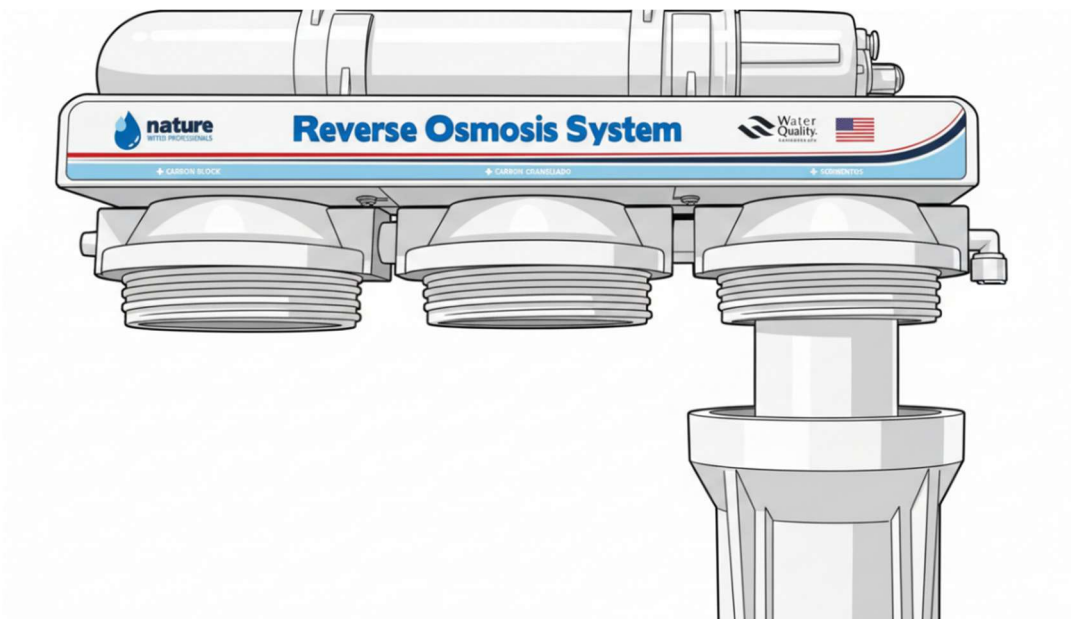

Subsequently, the same operation will be carried out with the other two filters, Granular Carbon and Carbon Block.

The only filter that has a specific sense for placement inside the vessel is the central filter, Granular Carbon. It must be installed, leaving the white rubber gasket at the top of the glass.



These two filters are recommended to be rinsed prior to installation to remove traces of carbon dust.

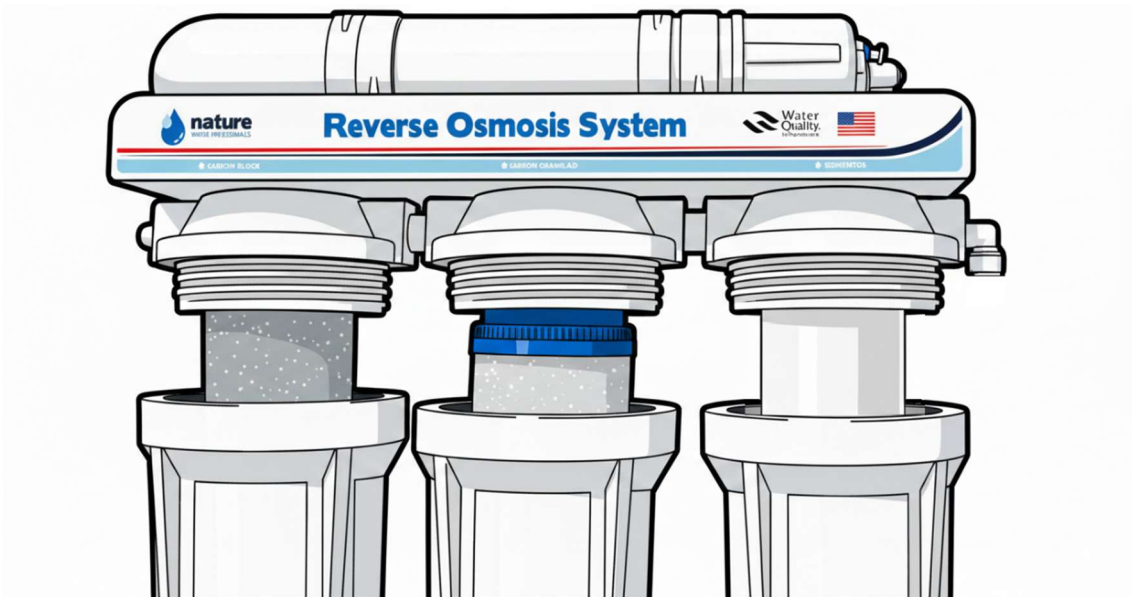

To change the post-filter, the pipes at the ends will be disconnected and thus free the filter. In the filter set you can find connections and Teflon. You can use the parts added in the kit or reuse those from your postfilter.

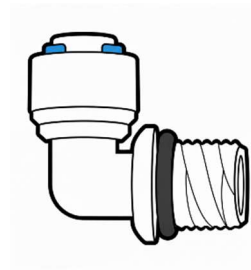
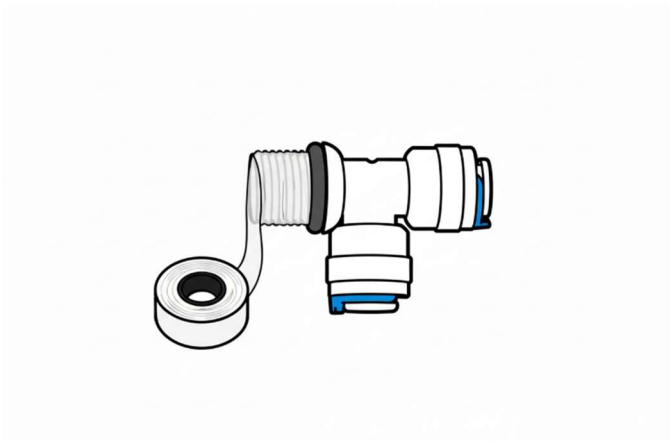

If you are using the supplied parts, you must first locate the T and one of the O-rings. Insert the gasket through the threaded part of the T until you reach the stop.

Unseal the filter, remove the side protective caps.

Apply 6/7 turns of Teflon to the thread, screw the T onto the end of the post-filter marked with the word "EQUIPMENT".



Locate an elbow, perform the same operation of inserting the O-ring and apply Teflon, screw on the end indicated with "TAP". From this elbow we will connect a piece of pipe to the inlet elbow of the remineralizing filter.



The supplied connections are quick to insert, for this the blue clips are removed, the pipe is inserted, exerting pressure to the top and reinserting the safety clips in place.

CONNECT TO THE WATER
INLET OF THE MINERAL FILTER

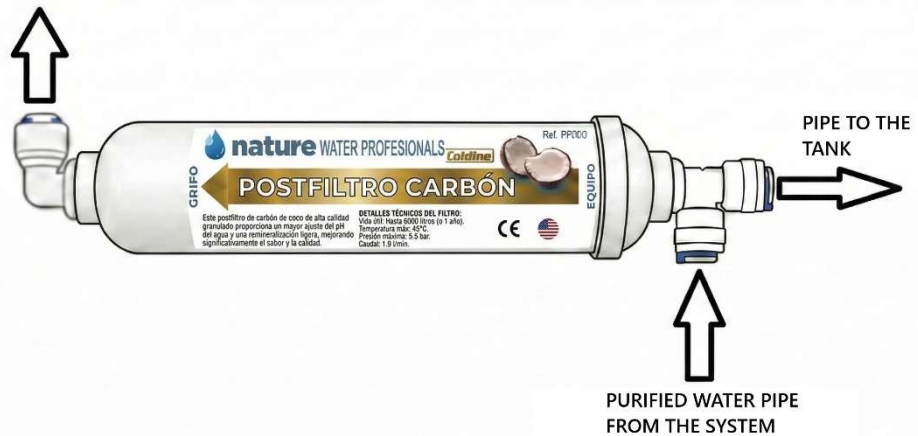

The pipe that comes from the membrane holder with the purified water and the pipe that connects to the tank must be connected to this tee.

For the installation of the remineralizing filter, the same operation will be carried out by inserting the black rubber gasket in the indicated place and applying several turns of Teflon. Then adjust with a small wrench.

CONNECT THE PIPE FROM
THE REVERSE OSMOSIS
TAPS





It will be checked that all the vessels have been closed securely and that all the connections are made.

SANITIZATION AND PROCESS COMPLETION

In the first glass, 250ml of 3% hydrogen peroxide (hydrogen peroxide) will be added inside the glass together with the sediment filter. The cup will be adjusted to its initial position with the key.

The osmosis water outlet tap will be closed, the osmosis socket inlet will be opened, if your equipment has a pump it will be connected to the electrical network. We will wait for the tank to fill up and the system to stop. Let the hydrogen peroxide act for 15-20 minutes. After this time, the system will be completely emptied, waiting for hardly any water to come out of the osmosis equipment tap. This rinse should be done 2 to 3 times to remove the sanitizing agent.

Once the rinses have been done, the water can be consumed.

- It is normal that the first time the equipment is rinsed the water has a grayish color, it is the carbon dust of the post-filter has to settle.
- It is normal that during the first days of use the water presents small translucent particles, they are air bubbles trapped in the system, letting the water stand for a few minutes disappears.
- If the taste or smell after changing the filters is not pleasant, perform some more rinsing, if it continues, do not consume the water and contact the technical assistance service.

ALMACEN OSMOSIS, SL.

CIF: B06976161

CALLE RIO VINALOPÓ, 15. NAVE D-10

46930 QUART DE POBLET, VALENCIA, SPAIN.

contacto@almacenosmosis.com

Phone: 960491493



nature[®]
WATER PROFESSIONALS